

Mega Tamper Evident Security Labels

*Mega Holographic
Labels*

*Mega Tamper
Evident Labels
Type TT*

*Mega Tamper
Evident Labels
Type PT*

*Mega Tamper
Evident Labels
Type NT*

*Mega Tyvek for
Strong Contenders*

*Mega Water
Sensitive Label*

Type NT

Non Transfer System



MSD Non-Transfer

0001

Typical Applications

Coin boxes; ATM cartridges; Airline Doors / Compartments; Motor Vehicle Doors / Compartments; Food and Beverage Containers; First Aid Boxes; Meters and Valves; Metal, Plastic or Glass containers.

Construction & Features

Matt polyester face material with highly visible security message which is revealed when seal is lifted. Trigger message can be OPEN VOID as standard or customisable message.

Non-Transfer Tamper Evident labels leave no residue on the substrate surface. This is ideal if the surface needs to be kept clean for cosmetic reasons.

Label face can be written on with normal ink pen. Serial number, company name and logo can be printed onto the label face as well. Barcode printing is optional. Customisable colors are available for large quantities.

Technical Sheet

	Product Code : NT 712 Z	NT Cold 712
Liner	: White PE release paper 150g/m2	White Glassine release paper 90g/m2
Carrier	: Printed Polyester after treatment thickness of 0.036mm	Printed Polyester after treatment thickness of 0.045mm
Description	: Traces of prints or patterns appear on carrier without any adhesive transferred to substrates when tape is removed. Trace performance 95%	Traces of prints or patterns appear on carrier without any adhesive transferred to substrates when tape is removed. Trace performance 95%
Size	: Customized sizes are available.	Customized sizes are available.
Colours	: Blue (Standard); Red, Green, Yellow, Silver and Transparent are optional.	Blue (Standard); Red, Green, Yellow, Silver and Transparent are optional.

Application Temperature : -18°C to 60°C

-40°C to 85°C. It is recommended to apply the label under room temperature before exposing to extreme temperatures

Characteristics	NT 712 Z	NT Cold 712
Total Thickness	0.090mm ~ 0.095mm	0.067mm ~ 0.075mm
Initial Tack <small>Test Standard : PSTC-6 #14ball</small>	< 10cm	< 5cm
Holding Power <small>Test Standard : PSTC-7</small>	> 24 hours (moving within 1 cm) 0.5kg/2.5cm x 2.5cm	> 48 hours (moving within 1 cm) 0.5kg/2.5cm x 2.5cm
Holding Power for Temp. Resist. 60 degrees Celsius <small>Test Standard : PSTC-7</small>	> 24 hours (moving within 1 cm) 0.5kg/2.5cm x 2.5cm	> 24 hours (moving within 1 cm) 0.5kg/2.5cm x 2.5cm
Adhesion <small>Test Standard : PSTC-1</small>	> 1000 g/2.5 cm > 89.06 OZ/in > 9.8 N/2.5 cm	> 900 ~ 1400 g/2.5 cm 31.74 ~ 49.38 OZ/in 8.78 ~ 13.66 N/2.5 cm

Remarks: 1. Testing Conditions: Lab Temperature 23 +/- 2 degrees celsius; 60% +/- 5%RH.
2. Preserve a constant temperature of 20 ~ 30 degrees celsius, avoid exposing to high humidity.
3. Under normal condition, it could be preserve for one year.

The Basic Performance of Pressure Sensitive Tapes

Tapes Structural Figures

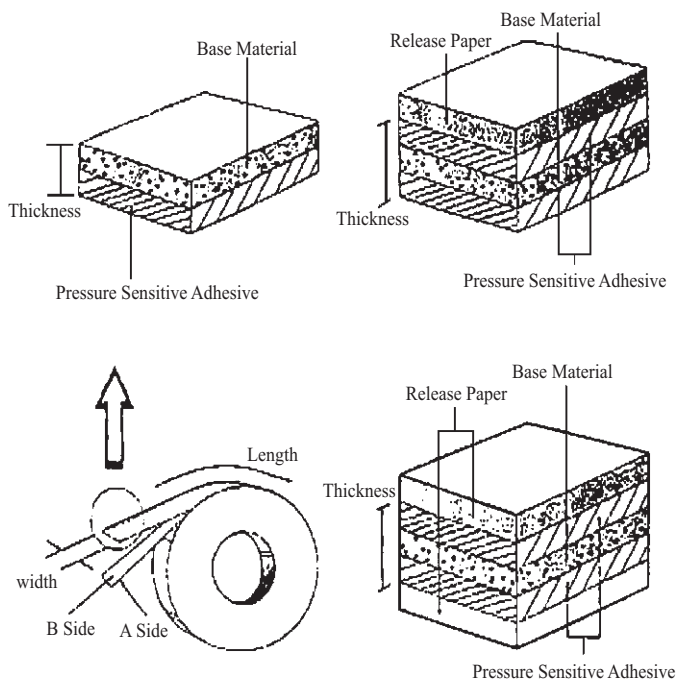

Peel Adhesion Test

- Test Standard: PSTC-1
- Adhesion to Steel Plate:
Adhere one end of the specimen to the test panel (SUS) Using a roller with constant force. After a period of time, clamp the SUS board. The tape specimen is pooled at an angle of 180°. Use the average pull value obtained as the adhesion value.
- A 2kg rubber roller is used to adhere the tape specimen on the SUS board that has been cleaned and dried according to the required standard (# 302 or # 304). Leave to stand for 20 minutes before testing.

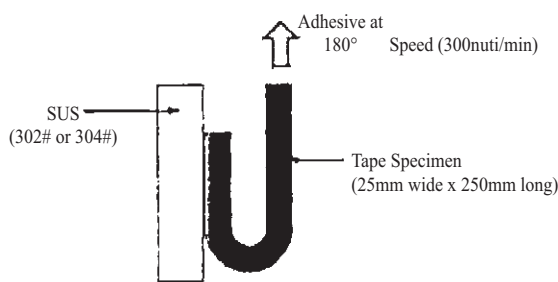

Initial Tack Test

- Test Standard: PSTC-6 (No. # 14 ball)

Initial Tack:

Arrange the tape specimen just removed from the roll adhesive side up in line with the raceway of the incline. Release the ball and allow it to roll to a stop on the adhesive. Measure the distance from the center of contact between the ball and adhesive to the near and of

- the incline.

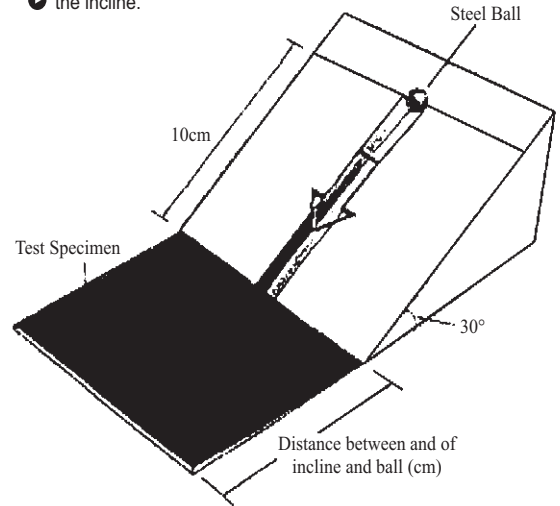

Holding Power Test

- Test Standard: PSTC-7
- Adhere the tape specimen to the test panel (SUS) using a roller with constant force. After a period of time, clamp the SUS board on the test stand so that the free end of the test specimen is vertical and apply the mass gently so as not to cause any shear impact force on the tape. Record the time elapsed in which the tape specimen completely separates from the test panel.
- A 2kg rubber roller is used to adhere the tape specimen on the SUS board that has cleaned and dried according to the required standard (# 302 or #304). Leave to stand for 20 minutes before testing.

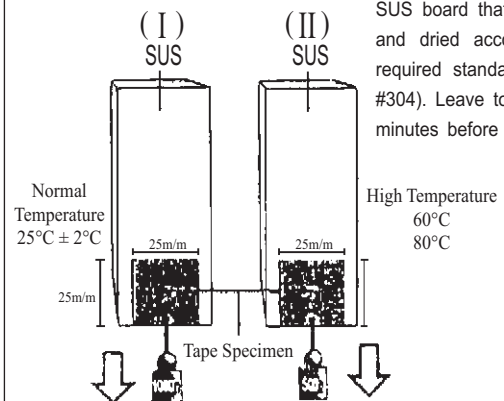

- ★ The above tests are carried out with equipment, materials, procedures and specifications in accordance to CNS or PSTC standards.
- ★ The performance results from the experiments carried out above are according to the tapes characteristics and specific conditions set and these are supplied as a reference only.

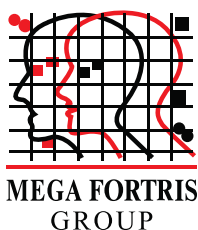

MEGA FORTRIS GROUP
PREVENTION PROTECTION PEACE OF MIND