

# Mega Tamper Evident Security Labels

*Mega Holographic  
Labels*

*Mega Tamper  
Evident Labels  
Type TT*

*Mega Tamper  
Evident Labels  
Type PT*

*Mega Tamper  
Evident Labels  
Type NT*

*Mega Tyvek for  
Strong Contenders*

*Mega Water  
Sensitive Label*

## Type TT

Total Transfer System



Label delaminates when lifted.  
This transfers all adhesive residue  
onto the applied surface.

### Typical Applications

Corrugated Carton Boxes; Security Envelopes; Wooden Crates; Coated Paper Boxes

### Construction & Features

Matt polyester face material with highly visible security message which is revealed when seal is lifted. Trigger message can be OPEN VOID as standard or customisable message.

When the TT label is lifted, the adhesive will be totally transferred to the applied surface. This is ideal when the applied surface is fibrous. Label face can be written on with normal ink pen. Serial number, company name and logo can be printed onto the label face as well. Barcode printing is an option. Customisable colors available for large quantities.

### Technical Sheet

<b>Product Code</b>	: TT
<b>Liner</b>	: Yellow PE release paper 150g/m <sup>2</sup> , White PE release paper 150g/m <sup>2</sup>
<b>Carrier</b>	: Printed Polyester after treatment thickness of 0.05mm
<b>Description</b>	: A dry strip of adhesive with prints or pattern is totally transferred to the item / article when applied.
<b>Size</b>	: Customized sizes are available.
<b>Colours</b>	: Red (Standard); Blue, Green, Yellow, Silver, Purple and Transparent are optional.
<b>Application Temperature</b>	: 0 degrees Celsius to 85 degree Celsius

### Characteristics

<b>Total Thickness</b>	0.080mm ~ 0.090mm		
<b>Initial Tack</b> Test Standard : PSTC-6 # 14ball	< 10cm		
<b>Holding Power</b> Test Standard : PSTC-7	> 24 hours (moving within 1 cm) 0.5kg/2.5cm x 2.5cm		
<b>Holding Power for Temp. Resist. 60 degrees Celsius</b> Test Standard : PSTC-7	> 24 hours (moving within 1 cm) 0.5kg/2.5cm x 2.5cm		
<b>Adhesion</b> Test Standard : PSTC-1	> 70 ~ 80 g/2.5 cm	> 6.3 ~ 8.1 OZ/in	> 0.7 ~ 0.9 N/2.5 cm

**Remarks:** 1. Testing Conditions: Lab Temperature 23 +/- 2 degrees celsius; 60% +/- 5%RH.  
2. Preserve a constant temperature of 20 ~ 30 degrees celsius, avoid exposing to high humidity.  
3. Under normal condition, it could be preserve for one year.

# The Basic Performance of Pressure Sensitive Tapes

## Tapes Structural Figures

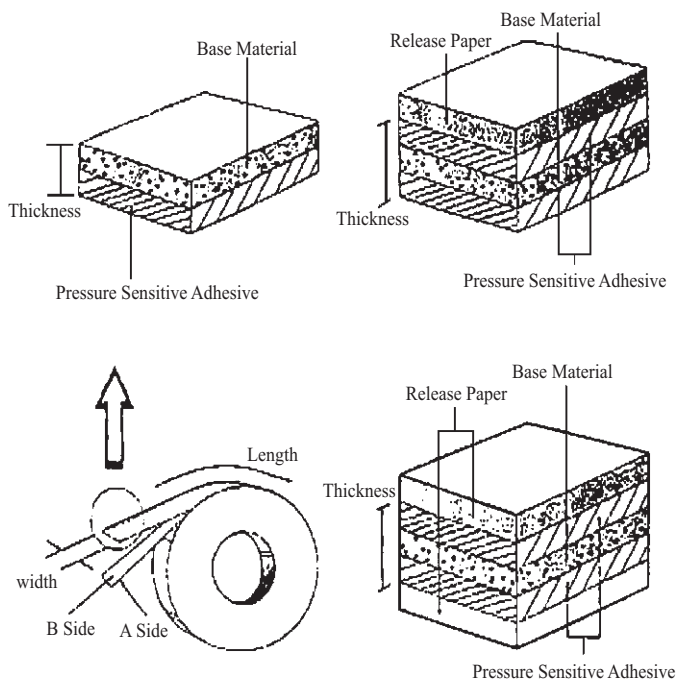

## Peel Adhesion Test

- Test Standard: PSTC-1
- Adhesion to Steel Plate:  
Adhere one end of the specimen to the test panel (SUS) Using a roller with constant force. After a period of time, clamp the SUS board. The tape specimen is pooled at an angle of 180°. Use the average pull value obtained as the adhesion value.
- A 2kg rubber roller is used to adhere the tape specimen on the SUS board that has been cleaned and dried according to the required standard (# 302 or # 304). Leave to stand for 20 minutes before testing.

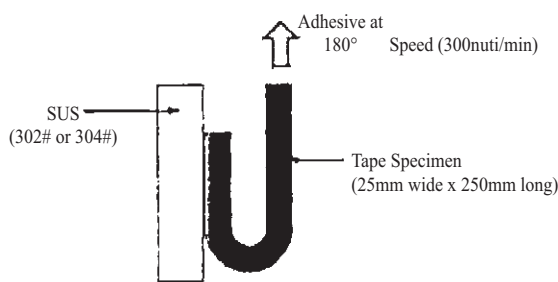

## Initial Tack Test

- Test Standard: PSTC-6 (No. # 14 ball)

Initial Tack:

Arrange the tape specimen just removed from the roll adhesive side up in line with the raceway of the incline. Release the ball and allow it to roll to a stop on the adhesive. Measure the distance from the center of contact between the ball and adhesive to the near and of

- the incline.

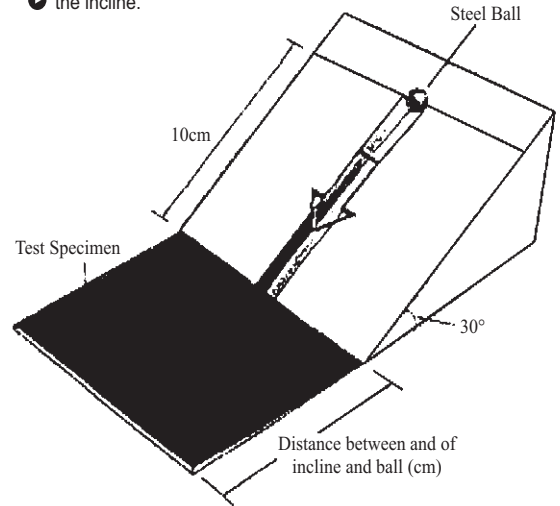

## Holding Power Test

- Test Standard: PSTC-7
- Adhere the tape specimen to the test panel (SUS) using a roller with constant force. After a period of time, clamp the SUS board on the test stand so that the free end of the test specimen is vertical and apply the mass gently so as not to cause any shear impact force on the tape. Record the time elapsed in which the tape specimen completely separates from the test panel.
- A 2kg rubber roller is used to adhere the tape specimen on the SUS board that has cleaned and dried according to the required standard (# 302 or #304). Leave to stand for 20 minutes before testing.

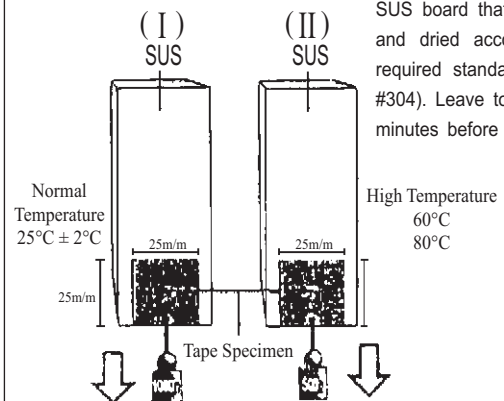

- ★ The above tests are carried out with equipment, materials, procedures and specifications in accordance to CNS or PSTC standards.
- ★ The performance results from the experiments carried out above are according to the tapes characteristics and specific conditions set and these are supplied as a reference only.

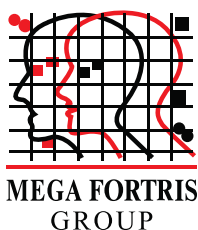

**MEGA FORTRIS GROUP**

**PREVENTION PROTECTION PEACE OF MIND**