



MEGA FORTRIS
G R O U P

Indicative Round Stem Pull Tight Seal · Data Sheet

Fast Seal 3.5



This product also able to be produced using **BioPlas** material except for any transparent product.

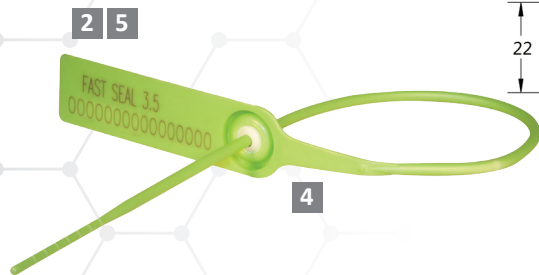
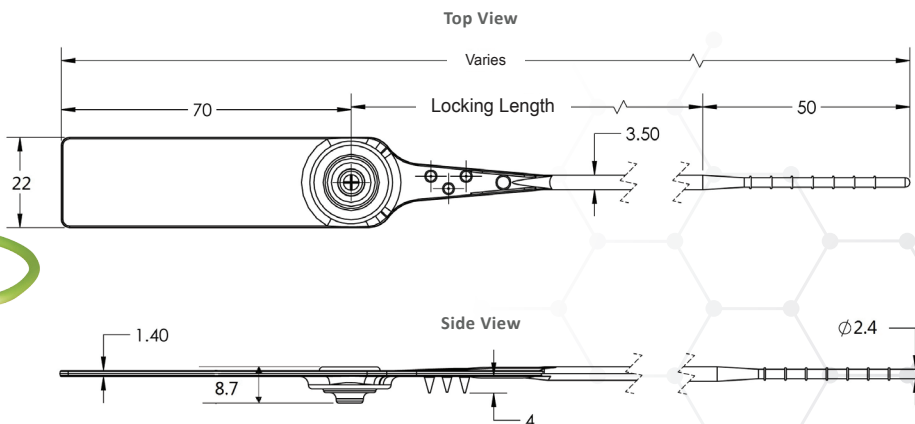

Indicative Round Stem Pull Tight Seal

Features

- 1 The Fast Seal 3.5 is a strong and durable seal designed for longer seal length and stronger sealing requirements.
- 2 The large flap area allows ample space for marking and barcoding.
- 3 The embedded spikes at the back of the seal provide better strapping grip on bags or other slippery materials.
- 4 A metal clip encapsulated by cap provides greater security and greater pull strength.
- 5 The Fast Seal 3.5 is etched with secure and permanent laser marking for name, logo, sequential numbers & barcodes. Laser marking offers the highest level of security as it cannot be removed or replaced without tamper evidence.
- 6 The options for durable Nylon or PP securing straps gives users different choices for strength customisation to match different applications.

Technical Specifications

PRODUCT - FAST SEAL 3.5

Product	Material	Locking Length	Strap Dimensions	Pull Strength	Marking Area	Max Marking Digits
RF3 300	Body: PP Coated & BioPlas Metal Plate: SS 304	300 mm (11.8 in)	∅ 3.5 mm (0.0137 in)	>30 kg (PP) (>66.1 lbs)	Flap: 50 x 18 mm (1.97 x 0.71 in)	Serial no : 16 Barcode no: 16
RF3 450	Cap: PP	450 mm (17.7 in)	∅ 3.5 mm (0.0137 in)	>35 kg (NY) (>77.1 lbs)		

PACKAGING

	Quantity	Dimensions (mm)	Gross Weight kg	Volume m ³
Inner Carton				
RF3 300	1,000	568 x 235 x 180 22.36 x 9.252 x 7.086 (in)	6.2 13.67 lbs	0.024 (0.848 cu.ft.)
RFS 450	1,000	615 x 280 x 280 24.21 x 11.02 x 11.02 (in)	7.7 16.98 lbs	0.048 (1.695 cu.ft.)
Standard Pallet				
RF3 300	72,000	1200 x 1000 x 1770 47.24 x 39.37 x 69.69 (in)	471.4 1039.3 lbs	2.124 (75.01 cu.ft.)
RFS 450	42,000	1230 x 1000 x 2110 48.42 x 39.37 x 83.07 (in)	348.8 768.97 lbs	2.612 (92.24 cu.ft.)

Standard Colours



KEY APPLICATIONS

- ✓ Cash in Transit
- ✓ Retails Applications
- ✓ Logistics
- ✓ Tankers
- ✓ Mail and Courier



FMM EXCELLENCE AWARD 2012
QUEST FOR CONTINUOUS IMPROVEMENT
BEST MANUFACTURER IN MALAYSIA IN 2012

UPDATED : 19 SEPTEMBER 2019